

Self-Propelled Telescopic Booms

S[®]-65 XC™

Specifications

Models	S-65 XC	
Measurements	Metric	US
Working height maximum*	21.81 m	71 ft
Platform height maximum	19.81 m	65 ft
Horizontal reach maximum	16.51 m	54 ft 2 in
Below ground reach	2.65 m	8 ft 8 in
A Platform length	0.91 m	3 ft
B Platform width	2.44 m	8 ft
C Height - stowed	2.81 m	9 ft 3 in
D Length - stowed	9.76 m	32 ft
Length, transport (jib tucked under)	7.80 m	25 ft 7 in
E Width	2.49 m	8 ft 2 in
F Wheelbase	2.50 m	8 ft 2 in
G Ground clearance - center	0.41 m	16.3 in

Productivity

Maximum lift capacity - unrestricted	300 kg	660 lbs
- restricted	454 kg	1,000 lbs
Platform rotation	160°	160°
Vertical jib rotation	133° (+ 79° / - 54°)	
Turntable rotation	360° continuous	
Turntable tailswing	1.41 m	4 ft 7.5 in
Drive speed - stowed	4.8 km/h	3.0 mph
- raised/extended	0.3 m/s	1 ft/s
Gradeability - stowed**	45%	45%
Turning radius - inside	2.40 m	7 ft 9 in
- outside	5.50 m	18 ft 2 in
Controls	12V DC proportional	
Tyres	355/55D 625	

Power

Power source	Deutz D2011L03i, 48 hp (36 kW)	
Auxiliary power unit	12V DC	12V DC
Hydraulic tank capacity	170 L	45 gal
Fuel tank capacity - diesel	132 L	35 gal

Weight***

4WD	11,673 kg	25,733 lbs
-----	-----------	------------

Standards Compliance

AS 1418.10

Range of Motion S-65 XC

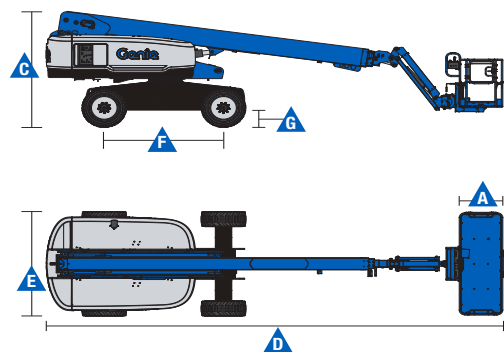
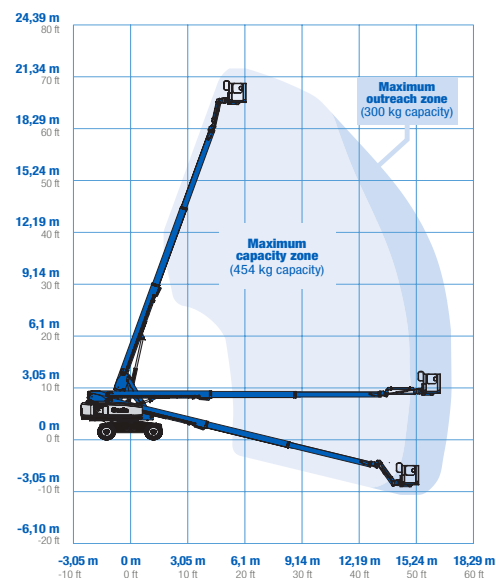

* The metric equivalent of working height adds 2 m to platform height. U.S. adds 6 ft to platform height.

** Gradeability applies to driving on slopes. See operator's manual for details regarding slope ratings.

*** Weight will vary depending on options and/or country standards.

Self-Propelled Telescopic Booms

S®-65 XC™

Features

Standard Features

Measurements

- 21.81 m (71 ft) working height
- 16.51 m (54 ft 2 in) horizontal reach
- 300 kg (660 lb) unrestricted and 454 kg (1,000 lb) restricted lift capacity

Productivity

- Automatic envelope control
- Self-leveling platform
- 160° hydraulic platform rotation
- Thumb rocker steering
- Proportional joystick controls
- Hydraulic oil cooler
- Drive enable system
- Chassis tilt drive function cut-out
- Horn
- Hour meter
- Descent and tilt alarm
- Flashing beacon & travel alarm
- 360° continuous turntable rotation
- Positive traction drive
- Two speed wheel motors
- On board full diagnostics and engine monitoring display
- Telematics ready connector
- Lift Guard™ Contact Alarm
- Work tray
- Lockable platform control box cover

Power

- 7.5 kW generator - 240 V / 50 Hz
- 12 V DC auxiliary power
- Anti-restart engine protection
- Auto engine fault shutdown
- Intake air heater
- Engine gauge package

Jib

- 1.52 m (5 ft) jib

Drive

- 4 x 4

Axle

- Active oscillation (standard)

Platform

- 2.44 m (8 ft) tri-entry platform with side swing gate

Engine

- Deutz diesel 48 hp (36 kW)



Options & Accessories

Productivity Options

- Half mesh platform inserts with side swing gate
- Airline to platform
- Work light package
- Biodegradable hydraulic oil
- Panel cradle package
- Pipe cradle
- Operator Protective Structure

Power Options

- Diesel catalytic purifier muffler

Tyre Options

- Rough terrain foam-filled (optional on Tyres)
- Rough terrain non-marking foam-filled (standard on Tyres)